

Meet KONA 3, the new heavyweight champion capture card for uncompressed SD, HD, and Dual Link HD on OSX. Visualize uncompressed video, 8-channel AES and embedded audio, up/down HD/SD format conversion, hardware downstream keyer, and HD/SD component analog output—all yours on a state-of-the-art 4-lane PCI Express card. Intrigued? Like other members of the KONA family, KONA 3 is designed for no-holds-barred design and editing—with support for Apple Final Cut Studio—plus hardware acceleration for the DVCPROHD and HDV codecs, and Dynamic RT Extreme effects in Final Cut Pro 5. It's a knockout—KONA 3—the new standard bearer for quality, flexibility, and future-safe architecture in a QuickTime I/O card.

KONA 3 Features:

- SDI, HD-SDI, Dual Link HD-SDI 4:4:4, and 4:4:4:4
- 4-Lane PCI-Express Bus Interface
- DVCPROHD hardware acceleration
- HDV hardware acceleration
- Dynamic RT Extreme hardware acceleration
- Broadcast Quality hardware 10-bit Up-convert
- Broadcast Quality hardware 10-bit Down-convert
- 12-bit HD component and SD component/composite analog output
- 10-bit HD/SD Video/Key Output
- Internal HD/SD Live Hardware Keyer
- 8-Channel 24-bit AES and Embedded Audio
- AJA QuickTime™ Drivers
- Apple Final Cut Pro 5™ Support
- Adobe AfterEffects, Photoshop Support... and Much More!
- RS-422 Machine Control
- Cables Standard—K3-Box Breakout Optional
- 3-year Warranty

Vroom!

KONA 3's 4-Lane PCI-Express bus interface with our own integrated AJA QuickTime™ drivers team up perfectly with the new Apple PowerMacs to give you unparalleled power and efficiency within Final Cut Pro. Supporting any uncompressed SD or HD format, including Dual Link, KONA 3 captures and plays back uncompressed 10-bit and 8-bit digital video and 24-bit 48kHz digital audio in standard definition (SMPTE 259M), high definition (SMPTE 292M), and Dual Link high definition (SMPTE 372M). KONA 3 also includes a variety of 10-bit broadcast-quality features, such as hardware-based up-and-down-conversion to and from HD—and adds a live hardware keyer for compositing bugs, live video, and other elements over your video.

Dual Link

KONA 3 supports Dual Link 4:4:4 HD-SDI, a new technology on the Macintosh platform. Commonly known as Sony HDCAM SR or Thompson Viper Format, KONA 3 Dual Link supports full bandwidth 4:4:4 RGB at 1080i, 1080p, and 720p formats. KONA 3 can also convert between 4:4:4 and 4:2:2 formats for single link HD-SDI output.

Broadcast-Quality Conversion

KONA 3 features full 10-bit, broadcast-quality, motion-adaptive SD to HD up-conversion, HD to SD down-conversion, and automatic HD/SD 2-bit component analog output. That's the equivalent of rolling AJA's stand-alone HD D/A converter, HD to SD downconverter, and our SD to HD up-converter into one convenient, cost-efficient KONA 3 board — at half the price. The quality is identical to AJA's award-winning stand-alone products, and all functionality is hardware-based, making it available full time, all the time, on digitize or playback.

Internal HD/SD Live Hardware Keyer

Available for the first time on any QuickTime capture card is a powerful hardware keyer that can place graphic files with an alpha channel over video in, a selectable matte, or the contents of the card's framebuffer (KONA TV/Final Cut Pro). If that weren't enough, you can also key video that has an alpha channel over video input or a matte. For example, you could load a QuickTime clip that has an alpha-channel—a flying logo perhaps—into KONA TV and then place it over live video coming into the card.

Audio

KONA 3's extensive audio support makes installation a breeze, working with 8-channel 24-bit 48kHz AES audio via XLR (balanced) connections, and 8-channel embedded 24-bit 48kHz embedded SDI/HD-SDI audio. KONA 3 also features high-quality input sample rate conversion on AES inputs, which eliminates the need for audio source synchronization.

If you're using a digital Betacam deck, HDCAM, DVCPRO HD, D5, D9, or even an HDCAM SR, you'll have the proper connections.

Flexible I/O

KONA 3 boasts two HD/SD SDI video inputs and outputs and a component analog output, each independently switchable between HD and SD (SD analog can be configured as composite). For example, if you are working in HD, you can have simultaneous HD-SDI, SDI, and HD or SD component analog output. You can also use the two SDI outputs for a split video and key output for use with switchers, DVEs, and other professional equipment. Using KONA 3's full-time format conversion features, monitoring can be as simple as a single composite monitor for both SD and HD projects. Dual Link can be monitored via Dual Link HD-SDI outputs, Single Link HD-SDI, or HD component analog.



KONA 3

Looking for unsurpassed cable connectivity? Well look no further, because when you plug in KONA 3's breakout cables, they automatically configure. For SDI video, the card features two HD/SD inputs and two outputs for Single or Dual Link, one connection for Genlock input, and three for HD/SD component analog video out. Also included is a 9-pin D connector for RS-422 machine control. The SDI inputs and outputs use a separate cable with special mini-BNC connectors on one end and full-sized BNCs on the other for ease of connection and superior reliability.

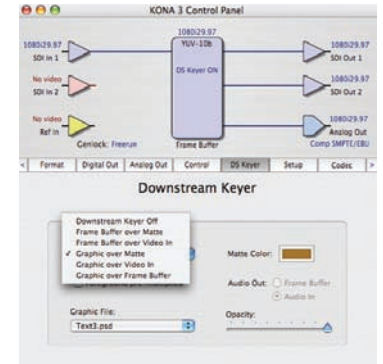

KONA 3 Control Panel

The **K3-Box** for KONA 3 simplifies interfacing by offering a 19-inch, 1RU rack-mountable breakout box that attaches to the KONA 3 with just two cables. This option offers all the same inputs and outputs as the standard breakout cable, and can be easily rack-mounted or placed on top of a broadcast monitor or editing desk. Additional functionality includes simultaneous XLR and BNC AES output, 2-channel RCA analog audio monitoring, and looping BNC Genlock reference connectors.

KONA Desktop

Most users run multiple applications to create their video projects. So in addition to Final Cut Pro 5 support, the KONA Desktop feature allows broadcast design elements to be viewed with the proper aspect ratio and color depth on a broadcast monitor via the KONA card. KONA Desktop is available on KONA 3, KONA LH and KONA LS, supporting Adobe After Effects, Adobe Photoshop, Apple Motion, Apple Shake, Discreet Combustion and more.

K3-Box for KONA 3



All AES/EBU audio connectors have two channels per connector
 AES/EBU Audio Out Channels 1 through 8
 Serial Digital Reference Out
 External Component/Composite Video Output
 Analog Audio Output

KONA 3 Specifications

Video Input

HD-SDI/SDI, SMPTE-259/292/296

Dual-link HD 4:4:4, 4:4:4:4

Dual-rate

Video Formats

525i 29.97

625i 25

720p 50

720p 59.94

720p 60

1080i 25

1080i 29.97

1080i 50

1080psf 23.98

1080psf 24

1080p 50

1080p 59.94

1080p 60

Video Output

Digital:

SD-SDI, SMPTE, 259M, 10-bits, BNC

HD-SDI SMPTE, 292/296, 10-bits, BNC

Dual-link HD 4:4:4

Analog: SD and HD Output, 12-bits, BNC

HD: YPbPr, RGB

SD: YPbPr, RGB (component mode)

Composite/YC (composite mode)

Downstream Keyer:

Will output graphics with alpha channel over video, matte or framebuffer, or framebuffer content over video or matte

Audio

24-bit embedded HD audio

20-bit SD embedded audio

24-bit AES audio

Up-Conversion

Hardware 10-bit

Anamorphic: full-screen

Pillar box 4:3: results in a 4:3 image in center of screen with black sidebars

Zoom 14:9: results in a 4:3 image zoomed slightly to fill a 14:9 image with black sidebars

Zoom Letterbox: results in image zoomed to fill full screen

Zoom Wide: results in a combination of zoom and horizontal stretch to fill a 16:9 screen; this setting can introduce a small aspect ratio change

Down-Conversion

Hardware 10-bit

Anamorphic: full-screen

Letterbox: image is reduced with black top and bottom added to image area with the aspect ratio preserved

Crop: image is cropped to fit new screen size

Reference Input

Analog Color Black (1V) or Composite Sync (2 or 4V)

Non terminating, Looping, 75 ohm

Machine Control

RS-422, Sony 9-pin protocol.

KONA 3 Standard XLR Breakout Cable

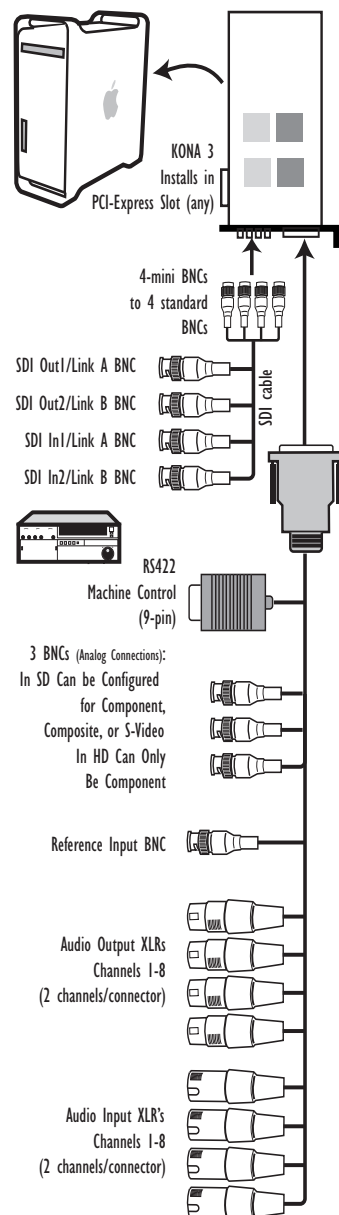

KONA 3 Hardware Acceleration

Final Cut Pro 5 users will love our DVCPROHD, HDV, and Apple Dynamic RT Extreme hardware acceleration, developed in close cooperation with Apple and available exclusively on high-end KONA cards. KONA 3 hardware takes a portion of the codec processing load off the CPU, allowing more Real Time effects in Final Cut Pro 5 when outputting. KONA 3 also has hardware support when capturing. This brings amazing RealTime HD production power to the desktop. With KONA 3, any source can be captured using the DVCPROHD codec—giving you online HD quality at remarkably low data rates, allowing the internal PowerMac SATA storage to be used for HD capture, playback, and RT effects. Of course, you'll obtain still better performance and more RT when using a fast SCSI or Fibre array, but this feature allows HD to be used where only SD would have been considered due to budget or time constraints. KONA 3 even supports the DVCPROHD and HDV codecs with up or down-conversion—allowing projects to be downconverted to SD, or even upconverted for DVCPROHD capture.

How does KONA Accelerate DVCPROHD, HDV, and Apple's Dynamic RT?

Because KONA's precision hardware does part of the work, the G5 has more

time available to process RT effects.

This means more RT effects power, and more RT streams. Most broadcast codecs, including DVCPROHD and HDV, use a two-step process. First the video is scaled to a lower horizontal pixel count, and then the video is compressed. This is done because the slightly scaled video results in a favorable trade-off between resolution and codec efficiency. KONA 3's hardware not only dramatically speeds up the scaling part of the job, but it's also done with full 10-bit broadcast quality.

When using the Final Cut Pro 5 HDV codec, the KONA 3 hardware acceleration allows instantaneous real-time playback for both monitoring and recording. Even KONA's downconverter works in real-time with HDV, allowing SD monitoring, dubs, or mastering. This KONA 3 functionality makes HDV a fully professional solution.

The Panasonic DVCPROHD format takes advantage of KONA hardware as well. KONA's precision hardware allows capture and playback of HD-SDI video to/from the DVCPROHD codec at a quality level virtually indistinguishable from native FireWire, while freeing up valuable RT processing power.

For Final Cut Pro 5's Dynamic RT feature, KONA's hardware is used to offload the video scaling as the "Playback Video Quality" dynamically

adjusts. This allows more playback power — and because KONA handles it seamlessly, the Dynamic RT you see on the Mac monitor is the same as that shown on your professional broadcast monitor.

KONA 3

All of this adds up to the most reliable, feature rich, and highest performance card available for OSX and Final Cut Pro. KONA 3 represents the next generation of technology from AJA.

Incredible 3 Year Warranty

AJA Video warrants that KONA products will be free from defects in materials and workmanship for a period of three years from the date of purchase.

About AJA Video Systems, Inc.

Since 1993, AJA Video has been a leading manufacturer of high-quality and cost-effective digital video interface, conversion and Desktop solutions supporting the professional broadcast and post-production markets. With headquarters in Grass Valley, California, AJA maintains an extensive sales channel of dealers and systems integrators around the world. For further information, please see our website www.aja.com.



KONA 3 Breakout Cables



AJA Video Systems Inc.
P.O. Box 1033 • Grass Valley, California 95945
800.251.4224 • 530.274.2048 • www.aja.com